

front end telescopic cylinders



ÖZÇELİKLER Hidrolik Silindir Sanayi ve Tic. Ltd. Şti.

1. Organize Sanayi Bölgesi Erkunt Caddesi

No: 18 06935 Sincan / Ankara - TÜRKİYE

Tel: +90 312 267 05 10 Fax: +90 312 267 05 15

www.ozceliklerhydraulic.com info@ozceliklerhydraulic.com



front end telescopic cylinders

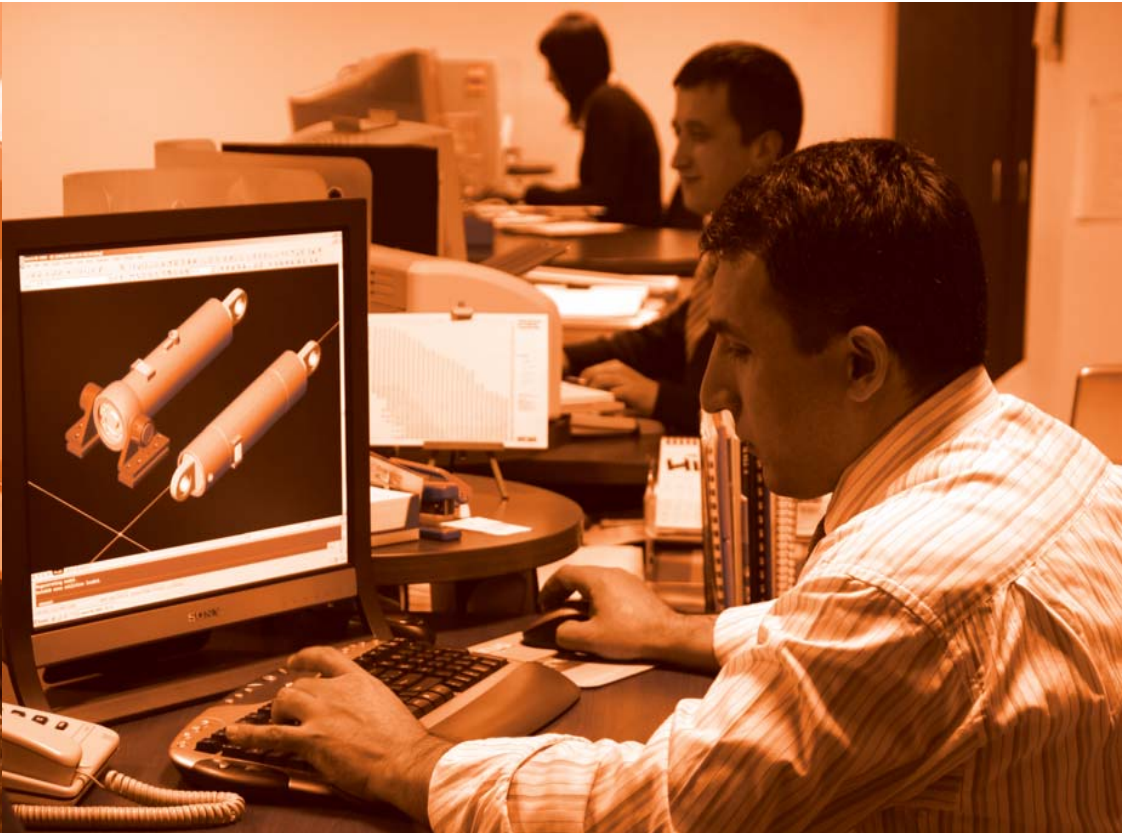

Önsöz

1975 yılından bu yana kalite anlayışını ve müşteri memnuniyetini her zaman en önde tutarak teknolojisini sürekli yenileyen firmamız bugün konusunda söz sahibi, sektörünün önde gelen kuruluşlarındandır.

Sizlerden aldığımız destekle yarınlara emin adımlarla ilerleyen firmamız, endüstriyel hidrolik silindir ve mobil hidrolik silindir üretiminin yanı sıra "Hydrotip" markası ile hidrolik damper teleskopik silindirlere de üretimini başarı ile yapmaktadır.

Siz değerli müşterilerimize bizlere verdiğiniz destekten dolayı teşekkür eder, sizlere her zaman en iyi hizmet ve kaliteyi sunmak için çalışacağımızı bilmenizi isteriz.

Preface

Özçelikler is one of the leader company of its market since 1975, whose priority is quality and customer satisfaction.

We are producing mobile and industrial hydraulic cylinders also with "Hydrotip" branded hydraulic truck tipper telescopic cylinders through with your support during our improvement to the future with strong steps.

We want to thank to all of our customers for their support and we want you to know that, we will keep working to give you best service and quality.

Tasarım gücümüz...

Siparişini aldığımız hidrolik silindirler, tasarım departmanında, uzman kadromuz tarafından, bilgisayar destekli programlar yardımı ile tasarlanıp, proses kontrolleri yapıldıktan sonra üretim bölümüne gönderilir.

Strong design potential...

Foundation of our products is founded in our Research & Development department by specialized staff. Designs are realizing on the special computer media and after processing works accomplished by the engineers, production begins in the production department.

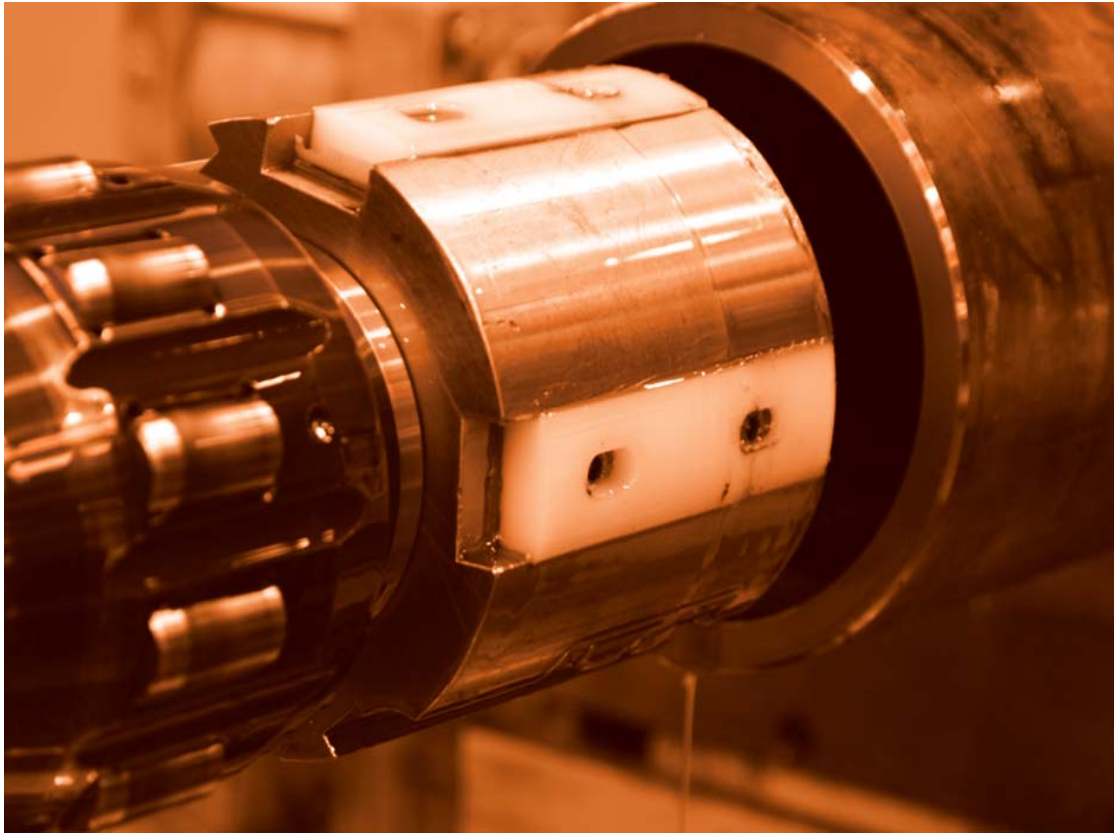

Başarıya giden yol...

Operasyon aşamaları belirlenmiş ürün, CNC kontrollü tezgahlarda üretilmektedir. Her operasyon sonrası ürün kontrolleri yapıлып, bir sonraki operasyona gönderilir. Boyutsal kontroller için kullanılan ölçü aletleri, periyodik olarak kalibre edilmektedir.

Road to success...

Operational stages determined product, is producing on the CNC controlled machines. After each operations product is controlled and send for a next operation. Measurement instruments used for size controls are calibrated periodically.

Kalite tutkumuz...

Özçelikler Hidrolik'te olmazsa olmazların en başında, asla taviz vermediğimiz kalite anlayışı gelir. Kalite kontrol biriminin onayını alan ürün montaj bölümüne gider. Montaj öncesi tüm parçalar itina ile temizlenerek, montaja hazır hale getirilir. Montaj işlemi, toz ve talaştan yalıtılmış ortamlarda gerçekleşir. Montajı tamamlanan silindirlere, yüzde yüz basınç ve kaçak testleri uygulanır. Ayrıca silindirler, müşterilerin isteği doğrultusunda omür testine de tabi tutulmaktadır. Test sonuçları raporlanarak müşteri firmaya gönderilir. Silindirler titizlikle boyanıp, ambalajlandıktan sonra sevke hazır hale getirilir.

Our quality passion...

Major Sine qua non of Özçelikler is quality understanding. Product approved by our quality control unit goes to assembly line. Before the assembly process, all the parts will be cleaned with care to make ready for mounting. Assembly process is made in the mediums free of dusts and metal fillings. On the assembly process accomplished cylinders, 100% pressure and leakage tests is applying. Also on the cylinders life test is applied according to the requirements of the customers. Test reports are sending to the customers. Cylinders are painting carefully, and after packaging they are ready for delivery.



Sevkiyat

Üretimimizin büyük bölümünü Avrupa ve Ortadoğu ülkelerine ihraç eden firmamız; testlerini ve son kontrollerini tamamladığı ürünleri; nakliye şekli, ürün özellikleri ve müşterilerimizin talep ettiği şekilde paketleyerek, uzun yıllar boyunca sorunsuz ve verimli bir şekilde hizmet verecekleri yerlere sevki eder.

Transporting

Özçelikler Hydraulic, exports a huge amount of its production, which have been totally tested and packed according to product specialties, delivery terms and customer wishes, to European and Middle East countries.

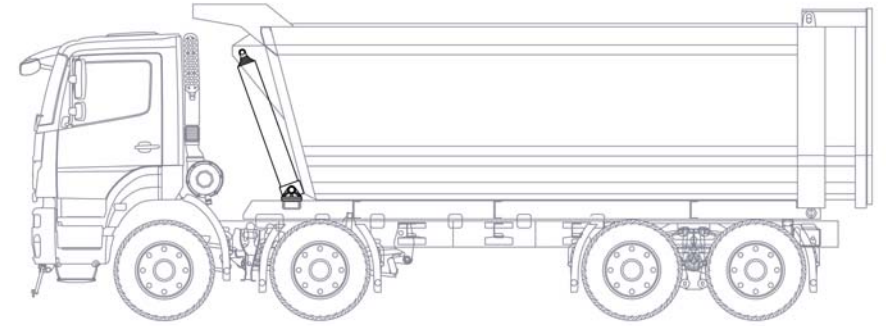

Silindirlerimizin önemli özellikleri.

* Üretilen tüm silindirler uzun yıllar sizlere daha iyi hizmet verebilmeleri için yüksek mukavemet değerlerine sahip dikişsiz soğuk çekme St 52 borulardan ileri teknoloji kullanılarak üretilmektedir.

* Ağır şartlarda ve yüksek basınç altında daha emniyetli kullanım sağlamak amacıyla tüm kademe borularının alt dayanak noktası ana malzemeden yekpare olarak üretilmektedir.

* Tüm silindirlerde daha verimli yataklama ve yanal yük kabiliyeti sağlamak amacıyla silindir stroklarına bağlı olarak değişken boylarda, hassas ve yüksek mukavemetli yataklama elemanları kullanılmaktadır.

* Tüm silindir boruları daha hassas çalışma boşlukları ve kaygan yüzeyleri elde etmek amacıyla kabuk soyarak parlatma teknolojisi ile işlenmektedir.

* Kademe borularının dış yüzeyleri daha iyisızdırmazlık performansını ve yüksek korozyon dayanımı sağlamak amacıyla süperfinish kalitesinde taşlanarak sert krom kaplanmaktadır.

* Her tür çalışma şartında yüksek performans gösteren ve uzun ömürlü olan sızdırmazlık tasarımı, kalitesini dünya pazarlarında kanıtlanmış firmaların ürünleri kullanılarak yapılmaktadır.

Important points of our cylinders.

* The cylinders are being produced from cold drawn seamless St 52 tubes those having higher strength properties with the help of high technology, in order to work on your vehicles long years without any problem.

* The bottom stoppers of all the stages are being produced from solid in order to work high pressures and heavy conditions.

* Accurate and high strength guiding elements which is proportional to stroke lengths of the cylinders are being used in order to have better guiding efficiency and stiffness.

* Stages are being machined by skiving and roller burnishing in order to provide closer tolerances and smoother sliding surfaces.

* In order to have better sealing wear resistance and higher corrosion resistance ; all the stages are being grinded, polishes and plated by hard chrome.

* The sealing design is being done by using the products of wellknown producers that is prove himself in world markets; in order to have long sealing life and efficiency under extreme conditions.

TELESKOPİK SİLİNDİR DEVRİLME AÇILARI

STROK	KASA BOYU	KASA BOYU	KASA BOYU	KASA BOYU	KASA BOYU	KASA BOYU	KASA BOYU	KASA BOYU	KASA BOYU	KASA BOYU	KASA BOYU	KASA BOYU
	3500	4000	4500	5000	5500	6000	6500	7000	7500	8000	8500	9000
2385	40,9	35,8										
2835	48,6	42,5										
3285	56,3	49,3	43,8	39,4								
3685		53,8	47,8	43,0								
3780			50,4	45,4								
3580			47,7	43,0								
3980			53,1	47,8	43,4							
4380			52,6	47,8	43,8	40,4						
4975			54,3	49,8	45,9	42,6	39,8					
5475				54,8	50,5	46,9	43,8	41,1	38,6	36,5		
5975					55,2	51,2	47,8	44,8	42,2	39,8		
6375						54,6	51,0	47,8	45,0	42,5		
6570							56,3	52,6	49,3	46,4	43,8	
6875								55,0	51,6	48,5	45,8	

BASINÇ DEĞERİNE GÖRE KUVVET (KG)

ROT ÇAPı mm	ÇALIŞMA BASINCI												
	80 BAR	90 BAR	100 BAR	110 BAR	120 BAR	130 BAR	140 BAR	150 BAR	160 BAR	170 BAR	180 BAR	190 BAR	
55	1901	2139	2376	2614	2851	3089	3327	3564	3802	4039	4277	4515	
75	3535	3977	4418	4860	5302	5744	6186	6628	7070	7511	7953	8395	
95	5671	6380	7089	7798	8507	9216	9925	10634	11343	12052	12760	13469	
115	8311	9349	10388	11427	12466	13505	14544	15582	16621	17660	18699	19738	
135	11453	12884	14316	15747	17179	18610	20042	21474	22905	24337	25768	27200	
155	15097	16984	18872	20759	22646	24533	26420	28307	30195	32082	33969	35856	
180	20360	22905	25450	27995	30540	33085	35630	38175	40720	43265	45810	48355	
205	26409	29710	33011	36312	39613	42914	46215	49516	52817	56118	59419	62720	

HİDROLİK TELESKOPİK SİLİNDİR KALDIRMA KAPASİTESİ ve KASA HACMİ

SİLİNDİR ADI	STROK (ST)	KASA / CASE					KALDIRMA KAPASİTESİ (TON)
		BOYU (KB)	MERKEZ (MB)	YÜKSEKLİK (KY)	ARKA BOY (AB)	HACMİ (m³)	
OK-3-2635-115-KR-RR-BR-RK	2835	3570	3300	800	450	7	10-14
OK-3-3285-135-KR-RR-BR-RK	3285	4820	4400	1000	600	11	16-22
OK-3-3585-135-KR-RR-BR-RK	3285	5170	4750	1200	600	15	22-30
OK-4-3580-135-KR-RR-BR-RK	3580	4790	4370	1200	600	14	21-28
OK-4-4380-135-KR-RR-BR-RK	4380	6230	5810	1200	600	18	27-36
OK-4-3580-155-KR-RR-BR-RK	3580	5380	5000	1200	600	15	22-30
OK-4-3980-155-KR-RR-BR-RK	3980	5830	5450	1200	600	16	24-32
OK-4-4380-155-KR-RR-BR-RK	4380	6380	5850	1200	600	18	27-36
OK-5-5475-180-KR-RR-BR-RK	5475	7870	7350	1300	750	24	36-48
OK-5-5975-180-KR-RR-BR-RK	5975	8770	8100	1300	900	27	40-54
OK-5-6375-180-KR-RR-BR-RK	6375	9420	8750	1300	900	29	44-58
OK-5-6875-180-KR-RR-BR-RK	6875	9920	9250	1300	900	30	45-60
OK-5-5475-205-KR-RR-BR-RK	5475	8020	7350	1500	750	28	42-56
OK-5-5975-205-KR-RR-BR-RK	5975	8120	7600	1500	750	29	44-58
OK-5-6375-205-KR-RR-BR-RK	6375	8770	8100	1500	900	31	46-62
OK-5-6875-205-KR-RR-BR-RK	6875	9420	8750	1500	900	33	50-66
OK-6-6570-205-KR-RR-BR-RK	6570	9920	9250	1500	900	35	52-70

HİDROLİK TELESKOPİK SİLİNDİR KODLAMA TABLOSU / CYLINDER CODE SYSTEM

Silindir Tipi Cylinder type	Kademe Sayısı Number Of Stages	Toplam Strok Total Stroke	1. Kademe Çapı First Stage	Bağlantı Tipi Mounting Type	Kapalı Boy Close Length
ÖK	4	3980	155	KR	L1297
ÖNDEN KALDIRMA / Front Lifting	7	BAKINIZ TABLO / Refer to the Table	205	KR	BAKINIZ TABLO / Refer to the Table
	6		180	RR	
	5		155	BR	
	4		135	RK	
	3		115		

SİLİNDİR BAĞLANTI TİPLERİ / CYLINDER MOUNTING TYPE



KR (1) KUŞAK RULMAN TRUNNION EYE	RR (2) RULMAN RULMAN EYE EYE	BR (3) BORU RULMAN PIPE EYE	RK (4) RULMAN KUŞAK EYE TRUNNION
----------------------------------------------	------------------------------------------	-----------------------------------------	----------------------------------------------

5 0 1 4 1 3 5 3 9 8 5

50	1	4	135	3985
GRUP	SİLİNDİR TİPİ	KADEME SAYISI	1. KADEME ÇAPı	STROK

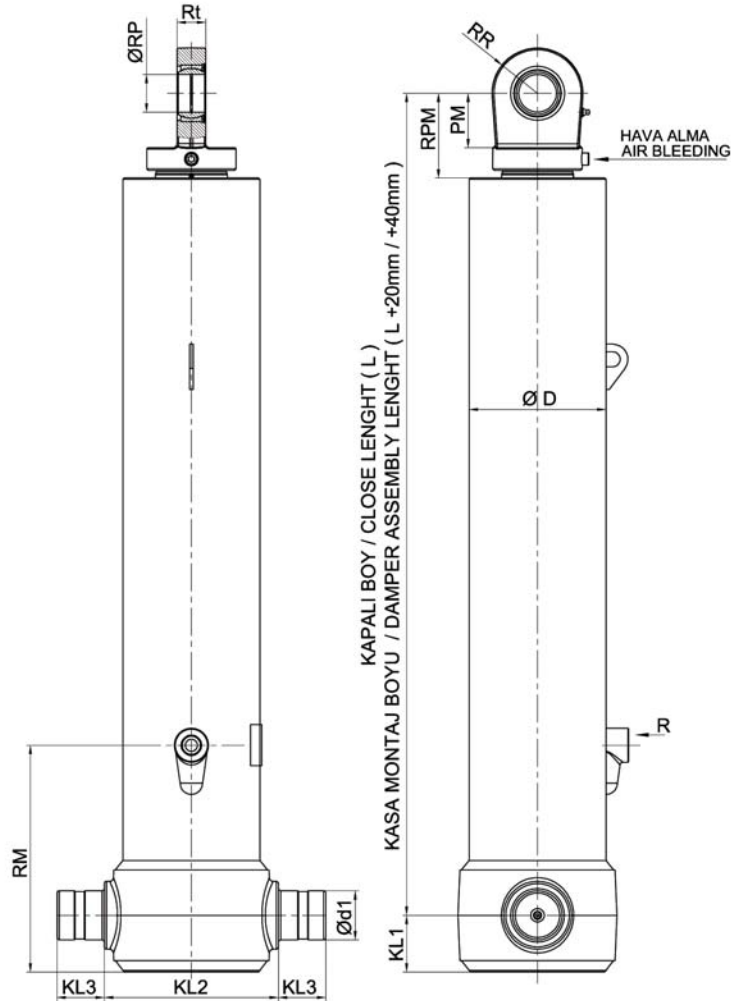

ÖLÇÜ TABLOSU / SIZE TABLE

SİLİNDİR STOK KODU	SİLİNDİR ADI	L	ØD	Rp	RPM	PM	Rt	Rr	Ød1	KL1	KL2	KL3	RM	R	YAĞ HACMI	AĞIRLIK Kg
50131152385	OK-3-2385-115-KR-L1105	1105	136	50	110	70	35	55	65	55	165	62,5	300	R3/4"	20	65
50131152835	OK-3-2835-115-KR-L1255	1255	136	50	110	70	35	55	65	55	165	62,5	300	R3/4"	23	70
50131353285	OK-3-3285-135-KR-L1397	1397	156	50	112	72	38	60	65	65	205	62,5	300	R3/4"	38	114
50131353585	OK-3-3585-135-KR-L1497	1497	156	50	112	72	38	60	65	65	205	62,5	300	R3/4"	42	150
50131553285	OK-3-3285-155-KR-L1420	1420	181	60	145	100	50	70	65	75	230	62,5	300	R3/4"	52	178

50141153780	OK-4-3780-115-KR-L1255	1255	136	50	110	70	35	55	65	55	165	62,5	300	R3/4"	27	80
50141353580	OK-4-3580-135-KR-L1195	1195	156	50	110	70	35	55	65	65	205	62,5	300	R3/4"	37	140
50141353780	OK-4-3780-135-KR-L1245	1245	156	50	110	70	35	55	65	65	205	62,5	300	R3/4"	39	144
50141353980	OK-4-3980-135-KR-L1295	1295	156	50	110	70	35	55	65	65	205	62,5	300	R3/4"	40	147
50141354380	OK-4-4380-135-KR-L1395	1395	156	50	110	70	35	55	65	65	205	62,5	300	R3/4"	45	154
50141553580	OK-4-3580-155-KR-L1187	1187	181	50	112	72	38	60	65	75	230	62,5	300	R3/4"	50	177
50141553780	OK-4-3780-155-KR-L1237	1237	181	50	112	72	38	60	65	75	230	62,5	300	R3/4"	53	182
50141553980	OK-4-3980-155-KR-L1287	1287	181	50	112	72	38	60	65	75	230	62,5	300	R3/4"	56	187
50141554380	OK-4-4380-155-KR-L1387	1387	181	50	112	72	38	60	65	75	230	62,5	300	R3/4"	61	197
50141554580	OK-4-4580-155-KR-L1437	1437	181	50	112	72	38	60	65	75	230	62,5	300	R3/4"	63	202
50141554780	OK-4-4780-155-KR-L1487	1487	181	50	112	72	38	60	65	75	230	62,5	300	R3/4"	65	207

50151554975	OK-5-4975-155-KR-L1285	1285	181	50	110	70	35	55	65	75	230	62,5	300	R3/4"	61	191
50151555475	OK-5-5475-155-KR-L1385	1385	181	50	110	70	35	55	65	75	230	62,5	300	R3/4"	67	206
50151804975	OK-5-4975-180-KR-L1292	1292	206	50	112	72	38	60	65	70	250	62,5	300	R1"	83	252
50151805475	OK-5-5475-180-KR-L1392	1392	206	50	112	72	38	60	65	70	250	62,5	300	R1"	91	265
50151805975	OK-5-5975-180-KR-L1492	1492	206	50	112	72	38	60	65	70	250	62,5	300	R1"	100	280
50151806375	OK-5-6375-180-KR-L1592	1592	206	50	112	72	38	60	65	70	250	62,5	300	R1"	105	294
50151806875	OK-5-6875-180-KR-L1692	1692	206	50	112	72	38	60	65	70	250	62,5	300	R1"	115	308
5015205475	OK-5-5475-205-KR-L1415	1415	231	60	145	100	50	70	65	80	290	67,5	300	R1"	120	325
50152055975	OK-5-5975-205-KR-L1515	1515	231	60	145	100	50	70	65	80	290	67,5	300	R1"	132	350
50152056375	OK-5-6375-205-KR-L1615	1615	231	60	145	100	50	70	65	80	290	67,5	300	R1"	140	375
50152056875	OK-5-6875-205-KR-L1715	1715	231	60	145	100	50	70	65	80	290	67,5	300	R1"	151	400

50161806570	OK-6-6570-180-KR-L1390	1390	206	50	110	70	35	55	65	70	250	62,5	300	R1"	96	300
50162056570	OK-6-6570-205-KR-L1382	1382	231	60	112	72	38	60	65	80	290	67,5	300	R1"	130	350

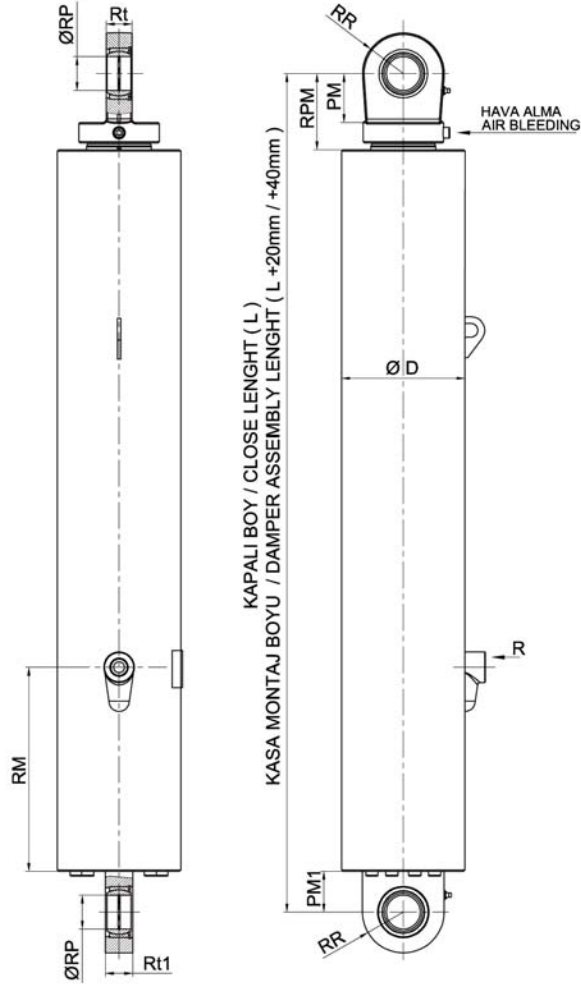

ÖLÇÜ TABLOSU / SIZE TABLE

SİLİNDİR STOK KODU	SİLİNDİR ADI	L	ØD	Rp	RPM	PM	Rt	Rt1	RR	PM1	RM	R	YAĞ HACMI	AĞIRLIK Kg
50231152385	OK-3-2385-115-RR-L1230	1230	136	50	110	70	35	35	55	60	300	R3/4"	20	65
50231152835	OK-3-2835-115-RR-L1380	1380	136	50	110	70	35	35	55	60	300	R3/4"	23	70
50231353285	OK-3-3285-135-RR-L1532	1532	156	50	112	72	38	35	60	60	300	R3/4"	38	114
50231353585	OK-3-3585-135-RR-L1632	1632	156	50	112	72	38	35	60	60	300	R3/4"	42	150
50231553285	OK-3-3285-155-RR-L1570	1570	181	60	145	100	50	40	70	65	300	R3/4"	52	178

50241153780	OK-4-3780-115-RR-L1380	1380	136	50	110	70	35	35	55	60	300	R3/4"	27	80
50241353580	OK-4-3580-135-RR-L1330	1330	156	50	110	70	35	35	55	60	300	R3/4"	37	138
50241353780	OK-4-3780-135-RR-L1380	1380	156	50	110	70	35	35	55	60	300	R3/4"	39	140
50241353980	OK-4-3980-135-RR-L1430	1430	156	50	110	70	35	35	55	60	300	R3/4"	40	145
50241354380	OK-4-4380-135-RR-L1530	1530	156	50	110	70	35	35	55	60	300	R3/4"	45	152
50241553580	OK-4-3580-155-RR-L1332	1332	181	50	112	72	38	40	60	60	300	R3/4"	50	170
50241553780	OK-4-3780-155-RR-L1382	1382	181	50	112	72	38	40	60	60	300	R3/4"	53	175
50241553980	OK-4-3980-155-RR-L1432	1432	181	50	112	72	38	40	60	60	300	R3/4"	56	180
50241554380	OK-4-4380-155-RR-L1532	1532	181	50	112	72	38	40	60	60	300	R3/4"	61	190
50241554580	OK-4-4580-155-RR-L1582	1582	181	50	112	72	38	40	60	60	300	R3/4"	63	195
50241554780	OK-4-4780-155-RR-L1632	1632	181	50	112	72	38	40	60	60	300	R3/4"	65	200

50251554975	OK-5-4975-155-RR-L1430	1430	181	50	110	70	35	40	55	60	300	R3/4"	61	185
50251555475	OK-5-5475-155-RR-L1530	1530	181	50	110	70	35	40	55	60	300	R3/4"	67	200
50251804975	OK-5-4975-180-RR-L1432	1432	206	50	112	72	38	40	60	60	300	R1"	83	245
50251805475	OK-5-5475-180-RR-L1532	1532	206	50	112	72	38	40	60	60	300	R1"	91	250
50251805975	OK-5-5975-180-RR-L1632	1632	206	50	112	72	38	40	60	60	300	R1"	100	275
50251806375	OK-5-6375-180-RR-L1732	1732	206	50	112	72	38	40	60	60	300	R1"	105	285
50251806875	OK-5-6875-180-RR-L1832	1832	206	50	112	72	38	40	60	60	300	R1"	115	290
50252055475	OK-5-5475-205-RR-L1570	1570	231	60	145	100	50	50	70	65	300	R1"	120	310
50252055975	OK-5-5975-205-RR-L1670	1670	231	60	145	100	50	50	70	65	300	R1"	132	330
50252056375	OK-5-6375-205-RR-L1770	1770	231	60	145	100	50	50	70	65	300	R1"	140	350
50252056875	OK-5-6875-205-RR-L1870	1870	231	60	145	100	50	50	70	65	300	R1"	151	380

50261806570	OK-6-6570-180-RR-L1535	1535	206	50	110	70	35	40	55	65	300	R1"	96	280
50262056570	OK-6-6570-205-RR-L1537	1537	231	60	112	72	38	40	60	65	300	R1"	130	310

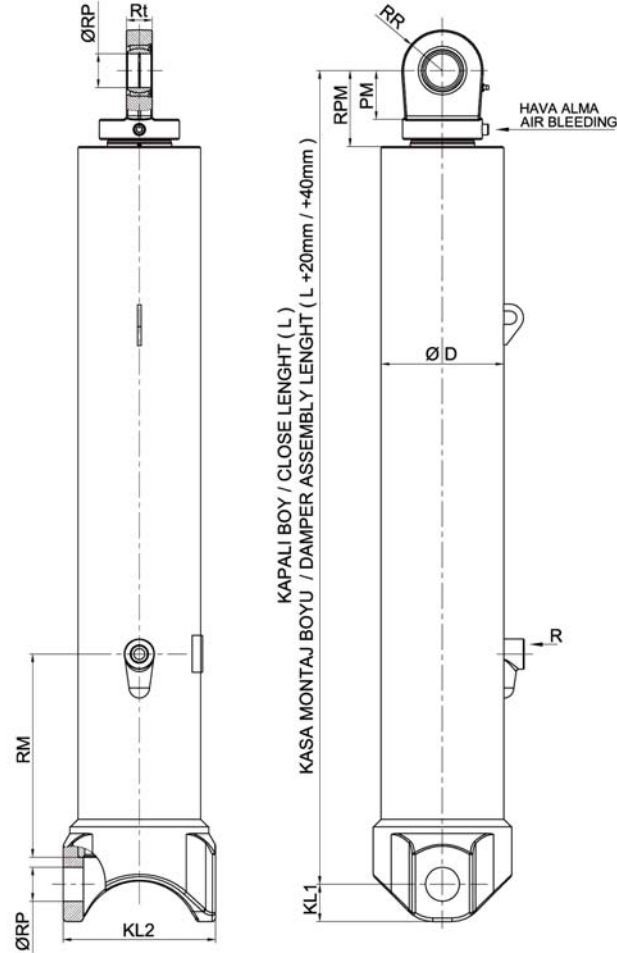

ÖLÇÜ TABLOSU / SIZE TABLE

SİLİNDİR STOK KODU	SİLİNDİR ADI	L	ØD	Rp	RPM	PM	Rt	RR	Ød1	KL1	KL2	RM	R	YAĞ HACMİ	AĞIRLIK Kg
50331152385	OK-3-2385-115-BR-L1200	1200	136	50	110	70	35	55	65	55	165	300	R3/4"	20	65
50331152835	OK-3-2835-115-BR-L1350	1350	136	50	110	70	35	55	65	55	165	300	R3/4"	23	70
50331353285	OK-3-3285-135-BR-L1502	1502	156	50	112	72	38	60	65	65	200	300	R3/4"	38	114
50331353585	OK-3-3585-135-BR-L1602	1602	156	50	112	72	38	60	65	65	200	300	R3/4"	42	150
50331553285	OK-3-3285-155-BR-L1535	1535	181	60	145	100	50	70	65	65	225	300	R3/4"	52	178

50341153780	OK-4-3780-115-BR-L1350	1350	136	50	110	70	35	55	65	55	165	300	R3/4"	27	80
50341353580	OK-4-3580-135-BR-L1300	1300	156	50	110	70	35	55	65	65	200	300	R3/4"	37	140
50341353780	OK-4-3780-135-BR-L1350	1350	156	50	110	70	35	55	65	65	200	300	R3/4"	39	144
50341353980	OK-4-3980-135-BR-L1400	1400	156	50	110	70	35	55	65	65	200	300	R3/4"	40	147
50341354380	OK-4-4380-135-BR-L1500	1500	156	50	110	70	35	55	65	65	200	300	R3/4"	45	154
50341553580	OK-4-3580-155-BR-L1302	1302	181	50	112	72	38	60	65	65	225	300	R3/4"	50	177
50341553780	OK-4-3780-155-BR-L1352	1352	181	50	112	72	38	60	65	65	225	300	R3/4"	53	182
50341553980	OK-4-3980-155-BR-L1402	1402	181	50	112	72	38	60	65	65	225	300	R3/4"	56	187
50341554380	OK-4-4380-155-BR-L1502	1502	181	50	112	72	38	60	65	65	225	300	R3/4"	61	197
50341554580	OK-4-4580-155-BR-L1552	1552	181	50	112	72	38	60	65	65	225	300	R3/4"	63	202
50341554780	OK-4-4780-155-BR-L1602	1602	181	50	112	72	38	60	65	65	225	300	R3/4"	65	207

50351554975	OK-5-4975-155-BR-L1400	1400	181	50	110	70	35	55	65	65	225	300	R3/4"	61	191
50351555475	OK-5-5475-155-BR-L1500	1500	181	50	110	70	35	55	65	65	225	300	R3/4"	67	206
50351804975	OK-5-4975-180-BR-L1407	1407	206	50	112	72	38	60	65	70	250	300	R1"	83	252
50351805475	OK-5-5475-180-BR-L1507	1507	206	50	112	72	38	60	65	70	250	300	R1"	91	265
50351805975	OK-5-5975-180-BR-L1607	1607	206	50	112	72	38	60	65	70	250	300	R1"	100	280
50351806375	OK-5-6375-180-BR-L1707	1707	206	50	112	72	38	60	65	70	250	300	R1"	105	294
50351806875	OK-5-6875-180-BR-L1807	1807	206	50	112	72	38	60	65	70	250	300	R1"	115	308
50352055475	OK-5-5475-205-BR-L1545	1545	231	60	145	100	50	70	65	80	290	300	R1"	120	325
50352055975	OK-5-5975-205-BR-L1645	1645	231	60	145	100	50	70	65	80	290	300	R1"	132	350
50352056375	OK-5-6375-205-BR-L1745	1745	231	60	145	100	50	70	65	80	290	300	R1"	140	375
50352056875	OK-5-6875-205-BR-L1845	1845	231	60	145	100	50	70	65	80	290	300	R1"	151	400

50361806570	OK-6-6570-180-BR-L1505	1505	206	50	110	70	35	55	65	70	250	300	R1"	96	300
50362056570	OK-6-6570-205-BR-L1512	1512	231	60	112	72	38	60	65	80	290	300	R1"	130	350

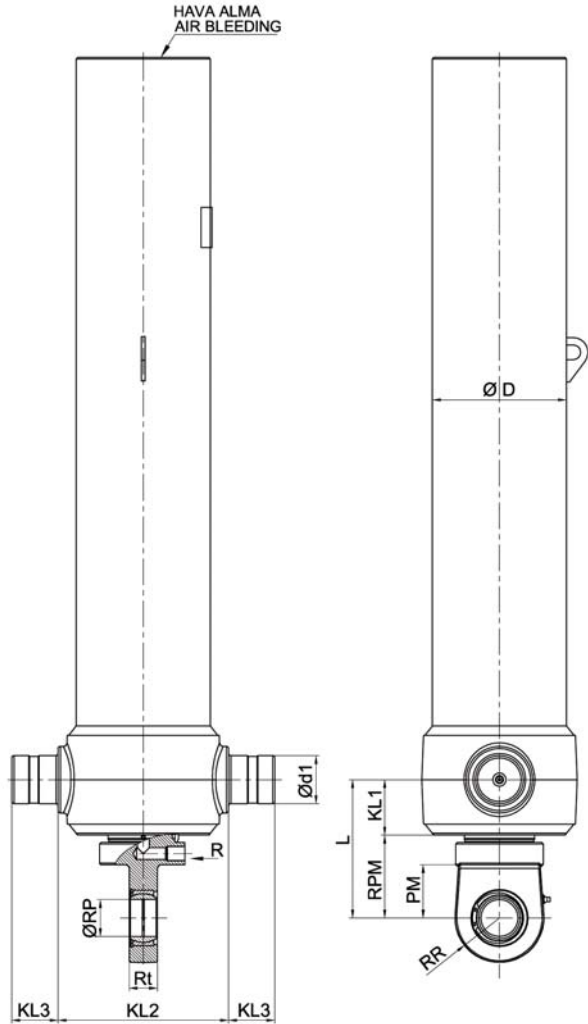

ÖLÇÜ TABLOSU / SIZE TABLE

SİLİNDİR STOK KODU	SİLİNDİR ADI	L	ØD	Rp	RPM	PM	Rt	RR	Ød1	KL1	KL2	KL3	RM	R	YAĞ HACMI	AĞIRLIK Kg
50431152385	OK-3-2385-115-RK-L165	165	136	50	110	70	35	55	65	55	165	62,5	300	R1/2"	20	65
50431152835	OK-3-2835-115-RK-L165	165	136	50	110	70	35	55	65	55	165	62,5	300	R1/2"	23	70
50431353285	OK-3-3285-135-RK-L177	177	156	50	112	72	38	60	65	65	200	62,5	300	R1/2"	38	114
50431353585	OK-3-3585-135-RK-L177	177	156	50	112	72	38	60	65	65	200	62,5	300	R1/2"	42	150
50431553285	OK-3-3285-155-RK-L210	210	181	60	145	100	50	70	65	65	225	62,5	300	R1/2"	52	178

50441153780	OK-4-3780-115-RK-L165	165	136	50	110	70	35	55	65	55	165	62,5	300	R1/2"	27	80
50441353580	OK-4-3580-135-RK-L175	175	156	50	110	70	35	55	65	65	200	62,5	300	R1/2"	37	140
50441353780	OK-4-3780-135-RK-L175	175	156	50	110	70	35	55	65	65	200	62,5	300	R1/2"	39	144
50441353980	OK-4-3980-135-RK-L175	175	156	50	110	70	35	55	65	65	200	62,5	300	R1/2"	40	147
50441354380	OK-4-4380-135-RK-L175	175	156	50	110	70	35	55	65	65	200	62,5	300	R1/2"	45	154
50441553580	OK-4-3580-155-RK-L177	177	181	50	112	72	38	60	65	65	225	62,5	300	R1/2"	50	177
50441553780	OK-4-3780-155-RK-L177	177	181	50	112	72	38	60	65	65	225	62,5	300	R1/2"	53	182
50441553980	OK-4-3980-155-RK-L177	177	181	50	112	72	38	60	65	65	225	62,5	300	R1/2"	56	187
50441554380	OK-4-4380-155-RK-L177	177	181	50	112	72	38	60	65	65	225	62,5	300	R1/2"	61	197
50441554580	OK-4-4580-155-RK-L177	177	181	50	112	72	38	60	65	65	225	62,5	300	R1/2"	63	202
50441554780	OK-4-4780-155-RK-L177	177	181	50	112	72	38	60	65	65	225	62,5	300	R1/2"	65	207

50451554975	OK-5-4975-155-RK-L175	175	181	50	110	70	35	55	65	65	225	62,5	300	R1/2"	61	191
50451555475	OK-5-5475-155-RK-L175	175	181	50	110	70	35	55	65	65	225	62,5	300	R1/2"	67	206
50451804975	OK-5-4975-180-RK-L182	182	206	50	112	72	38	60	65	70	250	62,5	300	R1/2"	83	252
50451805475	OK-5-5475-180-RK-L182	182	206	50	112	72	38	60	65	70	250	62,5	300	R1/2"	91	265
50451805975	OK-5-5975-180-RK-L182	182	206	50	112	72	38	60	65	70	250	62,5	300	R1/2"	100	280
50451806375	OK-5-6375-180-RK-L182	182	206	50	112	72	38	60	65	70	250	62,5	300	R1/2"	105	294
50451806875	OK-5-6875-180-RK-L182	182	206	50	112	72	38	60	65	70	250	62,5	300	R1/2"	115	308
50452055475	OK-5-5475-205-RK-L225	225	231	60	145	100	50	70	65	80	290	67,5	300	R1/2"	120	325
50452055975	OK-5-5975-205-RK-L225	225	231	60	145	100	50	70	65	80	290	67,5	300	R1/2"	132	350
50452056375	OK-5-6375-205-RK-L225	225	231	60	145	100	50	70	65	80	290	67,5	300	R1/2"	140	375
50452056875	OK-5-6875-205-RK-L225	225	231	60	145	100	50	70	65	80	290	67,5	300	R1/2"	151	400

50461806570	OK-6-6570-180-RK-L180	180	206	50	110	70	35	55	65	70	250	62,5	300	R1/2"	96	300
50462056570	OK-6-6570-205-RK-L192	192	231	60	112	72	38	60	65	80	290	67,5	300	R1/2"	130	350

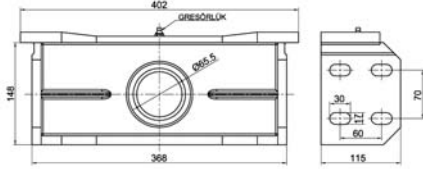

ÜRÜN ADI / PRODUCT NAME : ŞASE İÇİ BRAKET
 ÜRÜN KODU / PRODUCT CODE : ÖZC.BSA.65-368
 STOK KODU / STOCK CODE : 50000650368

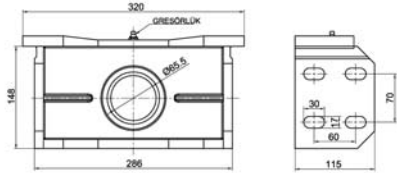
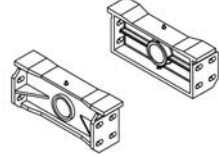

ÜRÜN ADI / PRODUCT NAME : ŞASE İÇİ BRAKET
 ÜRÜN KODU / PRODUCT CODE : ÖZC.BSA.65-286
 STOK KODU / STOCK CODE : 50000650286

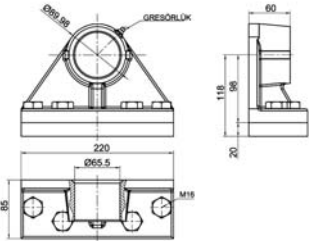
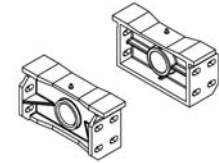

ÜRÜN ADI / PRODUCT NAME : ŞASE ÜSTÜ BRAKET
 ÜRÜN KODU / PRODUCT CODE : ÖZC.BSU.65-98
 STOK KODU / STOCK CODE : 5000065098

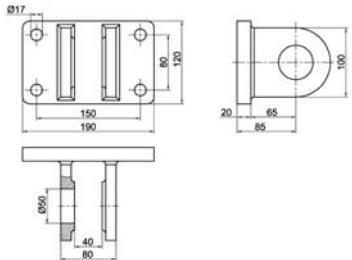
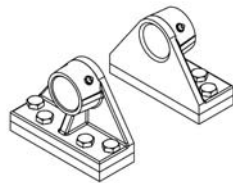

ÜRÜN ADI / PRODUCT NAME : ROT BAŞI BRAKET
 ÜRÜN KODU / PRODUCT CODE : ÖZC.BRB.50-65
 STOK KODU / STOCK CODE : 50000650065

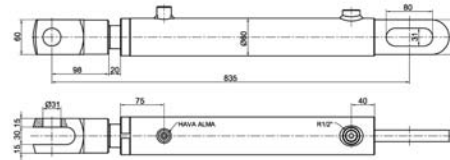
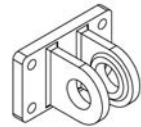

SİLİNDİR STOK KODU : 60105040500
 CYLINDER STOCK CODE :
 SİLİNDİR ADI : DKA-50-40-500-835
 CYLINDER NAME :

SİLİNDİR ÇAP / CYLINDER DIAMETER	50 mm
ROT ÇAP / ROD DIAMETER	40 mm
STROK / STROKE	500 mm
ÇALIŞMA BASINCI / WORKING PRESSURE	190 BAR
ÇALIŞMA SICAKLIĞI / WORKING TEMPERATURE	-20°C/+80°C
YAĞ HACMİ / OIL VOLUME	1 Lt
AĞIRLIK / WEIGHT	17 Kg.
İTME KUVVETİ / PUSH	3.7 TON/AD

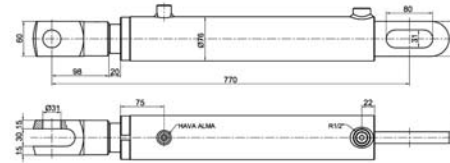

SİLİNDİR STOK KODU : 60116050450
 CYLINDER STOCK CODE :
 SİLİNDİR ADI : DKA-60-50-450-950
 CYLINDER NAME :

SİLİNDİR ÇAP / CYLINDER DIAMETER	60 mm
ROT ÇAP / ROD DIAMETER	50 mm
STROK / STROKE	450 mm
ÇALIŞMA BASINCI / WORKING PRESSURE	190 BAR
ÇALIŞMA SICAKLIĞI / WORKING TEMPERATURE	-20°C/+80°C
YAĞ HACMİ / OIL VOLUME	1.3 Lt
AĞIRLIK / WEIGHT	21 Kg.
İTME KUVVETİ / PUSH	5.3 TON/AD

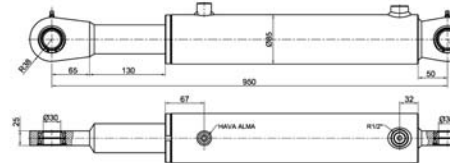

SİLİNDİR STOK KODU : 60127050550
 CYLINDER STOCK CODE :
 SİLİNDİR ADI : DKA-70-50-550-950
 CYLINDER NAME :

SİLİNDİR ÇAP / CYLINDER DIAMETER	70 mm
ROT ÇAP / ROD DIAMETER	50 mm
STROK / STROKE	550 mm
ÇALIŞMA BASINCI / WORKING PRESSURE	190 BAR
ÇALIŞMA SICAKLIĞI / WORKING TEMPERATURE	-20°C/+80°C
YAĞ HACMİ / OIL VOLUME	2.1 Lt
AĞIRLIK / WEIGHT	28 Kg.
İTME KUVVETİ / PUSH	7.3 TON/AD

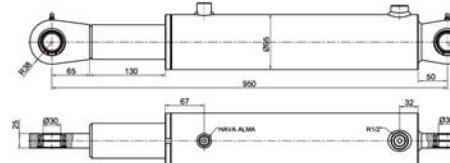

SİLİNDİR STOK KODU : 60138060550
 CYLINDER STOCK CODE :
 SİLİNDİR ADI : DKA-80-60-550-950
 CYLINDER NAME :

SİLİNDİR ÇAP / CYLINDER DIAMETER	80 mm
ROT ÇAP / ROD DIAMETER	60 mm
STROK / STROKE	550 mm
ÇALIŞMA BASINCI / WORKING PRESSURE	190 BAR
ÇALIŞMA SICAKLIĞI / WORKING TEMPERATURE	-20°C/+80°C
YAĞ HACMİ / OIL VOLUME	2.8 Lt
AĞIRLIK / WEIGHT	33 Kg.
İTME KUVVETİ / PUSH	9.8 TON/AD

